



**rewaco**<sup>®</sup>  
refreshes your life.  
Concessionario: Adolfo Piali  
tel: 3387105532  
mail: piali.adolfo@piali.it



***Perfectness in Motion.***

***Excalibur***<sup>®</sup>  
← SPORT & BUSINESS CARRIER



***Connect the beauty***



with the useful.

**Excalibur**  
SPORT & BUSINESS CARRIER

## No worries ...

Made and developed for any kind of daily loadings, but showing up with an extra-ordinary design of the elegant and aerodynamic fiberglass body.

The Excalibur trailer is available from 750 kg up to 1,800 kg gross weight.  
Transport your goods dry and safe!



Sports  
+  
Bikes

The ultimate way to transport your goods.  
Whatever you transport, either a go-kart, a motorcycle or bike, or even a hot-air balloon - the Excalibur trailer takes all those items safe and protected.

*... just carries!*

Using the Excalibur trailer for business purposes or just for fun - it is always an eye-catcher.



**SPORT & BUSINESS CARRIER**

Products  
+  
Business

Enjoy the additional benefit of that appealing travel companion as an ideal advertising medium - it is just unbeatable.

# Design and Colors!



Red White Grey Yellow

## Special colors



Silver-Metallic Black-Metallic Black Blue Customstyle

Two different sizes are available. For the measurements of the models S1 and S2, please, have a look at 'Technical Data'. Besides those options as brackets and clamps a business package with aluminium cover and integrated spare wheel holder is also available.

Type S1

Type S2

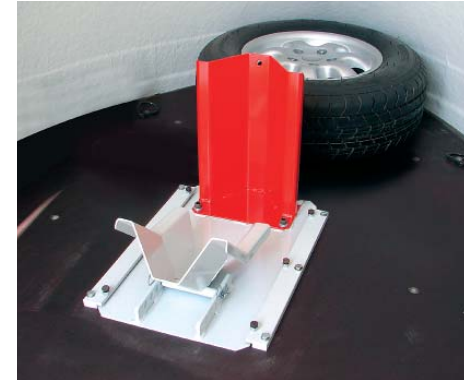

Motorcycle wheel chock



Tray for bikes higher than 150 cm

On inquiry we can offer further solutions to extend the usefulness of the trailer.



Business package with spare wheel



# Technical Data

## Body / Chassis:

Full fiberglass body

Frame: Hot-dip galvanized AL-KO frame

Chassis: Braked AL-KO axle with V-drawbar chassis

Model:	Type S1	Type S2
Variant:	750 / 1000 / 1200 / 1300 / 1500	1300 / 1500 / 1800
Length overall:	4780 mm	5205 mm
Length of body:	3610 mm	3970 mm
Width:	2080 mm	2480 mm
Height:	1970 mm	1990 mm
Net weight:	450 kg	550 kg / 570 kg
Gross weight:	750 / 1000 / 1200 / 1300 / 1500 kg	1300 / 1500 / 1800 kg
Tyres:	205/70-14 (750/1000/1200/1300) 205/65-15 (1500)	205/65-15 (1300/1500) 195/70-15 (1800)

## Equipment [standard]

- Flap roof with 2 gas pressure dampers
- Tailgate with 2 gas tension dampers
- Reverse light
- Rear fog light
- Additional brake light
- Inner light
- Crank-support at the rear
- Tailgate with central locking
- Tie-down rings 6 pcs. (10 pcs.)
- Overrun brake and handbrake

## Special equipment

- Alloy-wheels
- Business package
- Anti-theft device
- Loading support
- Tray (15 cm depth)
- Motorcycle wheel chock
- 100 km/h allowance in Germany
- Spare wheel
- Vario-rail for bike-fixing
- Bicycle holder
- Breakdown set

## Measurements: S1 / S2

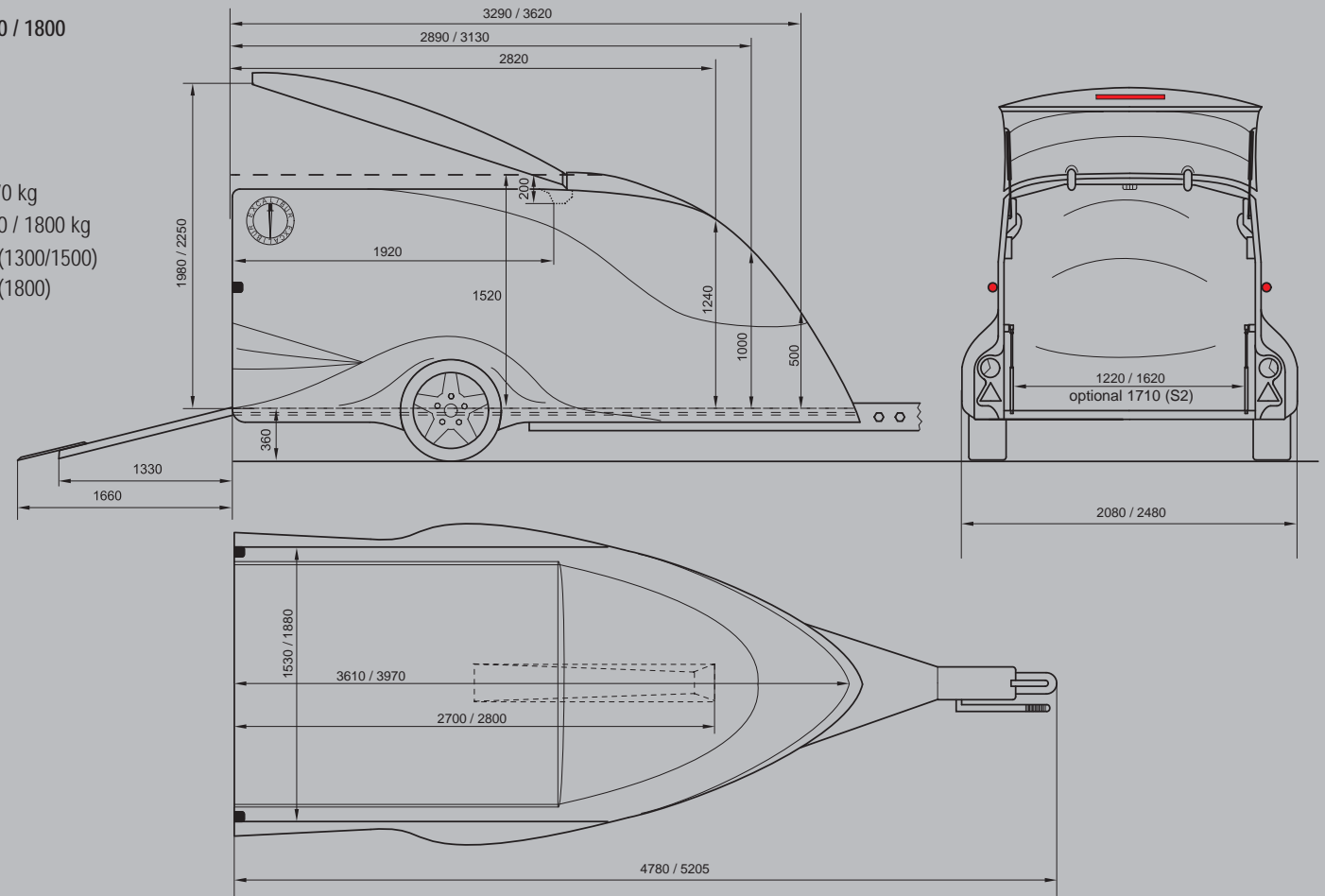

Further options and individual painting on inquiry after check of feasibility. Extra costs will be charged.  
The delivery will take place with a EC certificate of conformity (S1-750 with a German registration document)

# Just load 'n go!



The large tailgate and the flap roof allow easy access. The trailer also has superb handling qualities.

All information, photos, and technical details in this brochure are based on the latest stage prior printing. All rights to change technical and optical features are reserved.

**CONNECT THE BEAUTY  
WITH THE USEFUL.**

Your Excalibur Dealer

**rewaco** Italy  
gli specialisti del trike



Concessionario: ADOLFO PIALI CellularLine: 338-7105532  
Mail: [pialli.adolfo@pialli.it](mailto:pialli.adolfo@pialli.it)



**Excalibur**<sup>®</sup>  
SPORT & BUSINESS CARRIER

Concessionario Rewaco Piali Adolfo – [www.pialli.it](http://www.pialli.it)

Viale Belforte 62, 21100, Varese presso Diffusione Leasing (pretelefonare) - cell. 3387105532 - mail: [pialli.adolfo@pialli.it](mailto:pialli.adolfo@pialli.it)